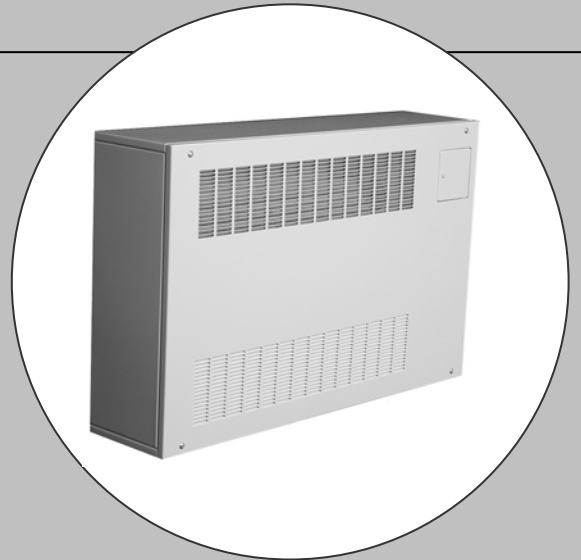


# Aéroconvecteurs / Force Flow Heaters

Catalogue / Catalog

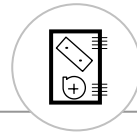


**MANUFACTURERS**

**OF HYDRONIC**

**HEATING**

**PRODUCTS**



# Force Flow Heaters

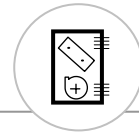
Sigma force flow cabinet unit heaters are styled to fit into any room and provide efficient, individualized room temperature control.

Sigma force flow heaters have been designed so that as the unit size increases, the depth and height of the units remains constant. Only the length of the unit increases with capacity, resulting in uniform heights between models.

The standard cabinet is easily installed and may be ordered in any of several different airflow configurations. Installation collars shipped with recessed models provide further standardization and product simplification. These collars are field installed permitting units to be fully or partially recessed to suit field conditions and are adaptable to both floor mount or above-floor installations.

Force flow cabinet heaters are available in various standard finishes, from the economical primer finish to a choice of industry-standard baked enamel colours. Custom baked enamel colours are available upon request.

Force flow cabinet heaters are also available with various options including : 1) an infinitely variable motor speed controller, 2) unit or remote mounted temperature controls to cycle fan on demand, 3) an aquastat override which disables unit operation when the hot water supply temperature is below 85 DegF, 4) motor starter (with or without overloads) and 5) safety chains for ceiling hung units.



### CABINETS

The outer cabinet is constructed from heavy duty corrosion resistant 16 Ga steel. The removable front panel provides uninhibited access to the internal structure for servicing the motor, fans, controls and coil. Cabinets are available in a left or right hand configurations. Cabinets have a standard factory finish in grey primer. Cabinets are also available with standard or custom color baked enamel finishes.

### COILS

Heating coils are manufactured from 1/2" outside diameter seamless copper tubes which are expanded within corrugated aluminum fins. This forced expansion within a restrictive frame creates a durable mechanical bond between the fins and tube. This bond means there is no movement of the fin on the tube and no rattling noises as air is forced through the coil. The coils are designed for working pressures up to 150 psi.

### BLOWERS

Twin centrifugal double-inlet double-width fans are mounted onto double-shafted motors for quiet operation and optimum airflow distribution across the coil and through the unit. The 1200 and 1500 cfm units employ a pair of twin fan & motor assemblies. All fan wheels and fan housings are corrosion resistant.

### MOTORS

Permanent split capacitor type motors with self aligning sleeve bearings for durable motor life, low operating cost and reduced noise levels. A motor controller provides infinitely adjustable blower speed.

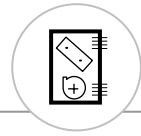
### FILTERS

All units are supplied with wire framed polyester media filters as standard. These filters are designed for quick and cost effective replacement within all units.

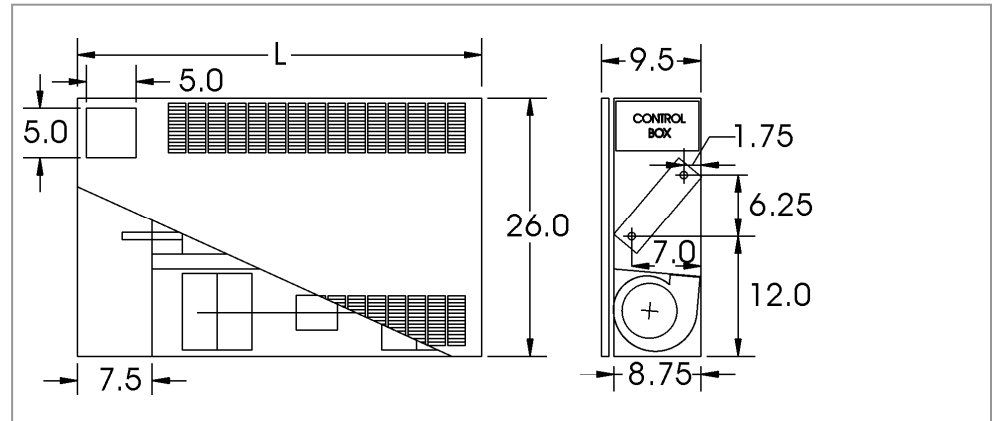
### CONTROLS

Force flow units are offered with the following control options:

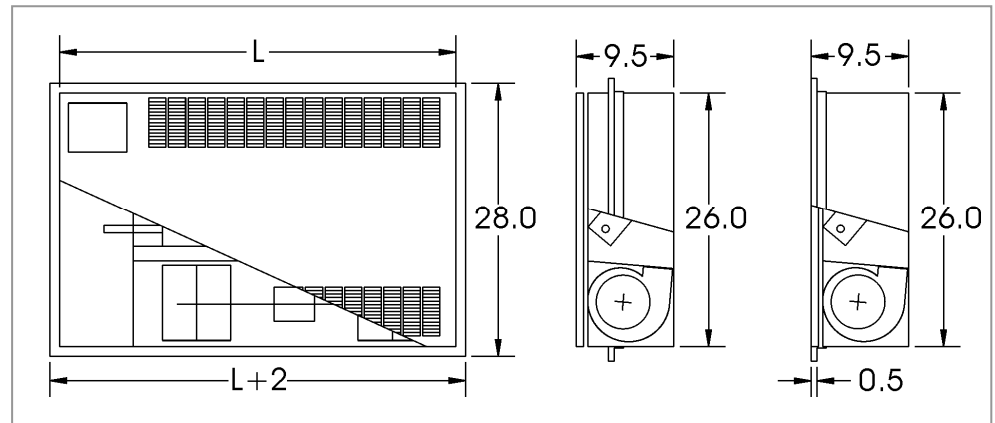
1. Motor Speed Control with On/Off Switch
2. Built-In Thermostat (1 Stage )
3. Remote Thermostat (1 Stage)
4. Motor Starter with/without Overloads
5. Aquastat Override



**FIGURE 1**  
**FULLY EXPOSED**  
**ELEVATION & SIDE VIEW**

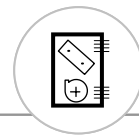


**FIGURE 2**  
**SEMI-RECESSED TO FULLY**  
**RECESSED ELEVATION &**  
**SIDE VIEW**



**TABLE 1**      **MODEL DIMENSIONS**

MODEL	NOMINAL AIR FLOW (CFM)	NO. OF MOTORS	MOTOR POWER (HP)	MOTOR SPEED (RPM)	MOTOR CURRENT (AMPS)	NO. OF FANS	LENGTH "L" (IN)	DUCT COLLAR SIZE (IN)	FILTER SIZE (IN)	TOTAL WEIGHT (LB)
SFF-A-02	200	1	1/10	1075	1.9	1	26.0	5 x 14	7.5 x 18	75
SFF-A-03	300									
SFF-A-04	400									
SFF-A-06	600					2	40.5	5 x 28	7.5 x 32	125
SFF-A-08	800									
SFF-A-10	1000									
SFF-A-12	1200	2	2x1/10	1625	3.8	4	70.5	5 x 58	7.5 x 62	200
SFF-A-15	1500		2x1/6		4.4					

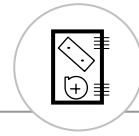


1. If required selection is at tabulated conditions (200/180/160°F EWT, 60°F EAT & 20/30/40°F  $\Delta T$ ), then the resulting performance can be looked up directly from the Heating Performance Data (Table 2).
2. If the conditions are as above but with a non-standard  $\Delta T$ , then the performance can be interpolated from data in Table 2 between the adjacent  $\Delta T$  values.
3. If required selection is not at tabulated conditions (200/180/160 °F EWT, 60°F EAT), one must first calculate the equivalent required performance at standard conditions (180°F EWT & 60°F) by applying a Correction Factor from Table 3, then lookup in the Heating Performance Data (Table 2) under 180°F EWT to find the unit which best matches the equivalent required capacity at the same gpm (See example on page 5).

**TABLE 2 FORCE FLOW HEATERS PERFORMANCE DATA AT 60°F ENTERING AIR TEMPERATURE**

MODEL	AIR FLOW (CFM)	WTD (°F)	200° F EWT				180° F EWT				160° F EWT			
			CAP. (MBH)	FLOW (GPM)	WPD (FT WG)	LAT (°F)	CAP. (MBH)	FLOW (GPM)	WPD (FT WG)	LAT (°F)	CAP. (MBH)	FLOW (GPM)	WPD (FT WG)	LAT (°F)
SFF02	220	20	19.4	1.95	0.8	142	16.2	1.62	0.6	128	13.0	1.30	0.4	115
		30	18.2	1.22	0.4	137	15.0	1.00	0.3	123	11.7	0.78	0.2	109
		40	17.0	0.85	0.2	132	13.6	0.68	0.1	117	10.3	0.52	0.1	103
SFF03	300	20	30.7	3.07	2.4	155	25.9	2.59	1.8	140	21.0	2.10	1.2	125
		30	29.4	1.96	1.1	151	24.5	1.63	0.8	136	19.6	1.31	0.5	120
		40	28.1	1.40	0.6	147	23.2	1.19	0.4	132	18.0	0.90	0.3	116
SFF04	400	20	38.0	3.80	3.5	148	32.0	3.20	2.6	134	25.9	2.59	1.8	120
		30	36.3	2.42	1.6	144	30.2	2.01	1.1	130	24.0	1.60	0.8	116
		40	34.5	1.73	0.9	140	28.3	1.42	0.6	126	22.0	1.10	0.4	111
SFF06	600	20	50.6	5.06	5.8	138	42.5	4.25	4.3	126	34.3	3.43	2.9	113
		30	48.1	3.21	2.6	134	39.9	2.66	1.9	122	31.7	2.11	1.2	109
		40	45.5	2.28	1.4	130	37.2	1.86	1.0	117	28.9	1.44	0.6	105
SFF08	800	20	66.9	6.69	1.6	137	56.0	5.60	1.1	125	45.0	4.50	0.8	112
		30	63.1	4.21	0.7	133	52.1	3.47	0.5	120	41.0	2.73	0.3	107
		40	59.3	2.97	0.4	129	48.1	2.41	0.3	116	36.8	1.84	0.2	103
SFF10	1000	20	77.7	7.77	2.0	132	64.9	6.49	1.5	120	52.1	5.21	1.0	108
		30	73.1	4.88	0.9	128	60.2	4.02	0.6	116	47.3	3.15	0.4	104
		40	68.6	3.43	0.5	123	55.5	2.77	0.3	111	42.4	2.12	0.2	99
SFF12	1200	20	103.0	10.30	4.5	140	86.6	8.66	3.3	127	70.1	7.01	2.3	114
		30	98.1	6.54	2.0	136	81.5	5.43	1.4	123	64.8	4.32	1.0	110
		40	93.0	4.65	1.1	132	76.2	3.81	0.8	119	59.2	2.96	0.5	106
SFF15	1500	20	119.8	12.00	5.9	134	100.7	10.10	4.3	122	81.4	8.14	3.0	110
		30	113.9	7.59	2.6	130	94.5	6.30	1.9	118	75.0	5.00	1.2	106
		40	107.8	5.39	1.4	127	88.2	4.41	1.0	114	68.4	3.42	0.6	102

Notes: EWT = Entering Water Temperature; LAT = Leaving Air Temperature



### DESIGN CONDITIONS

Heating Load = 52.0 MbH  
 Entering Water Temp. = 215°F  
 Water Temp. Drop = 40°F  
 Entering Air Temp. = 55°F

### REQUIRED EQUIVALENT CAPACITY (AT 180°F EWT / 60°F EAT)

From Table 3, since there are no factors for 55°F entering air, nor any for 215°F entering water, the correction factor must be interpolated across the pertinent downward diagonal as follows:

Factor at 50°F EAT & 210°F EWT= 1.342  
 Factor at 60°F EAT & 220°F EWT= 1.347  
 Factor at 55°F EAT & 215°F EWT(Average) = 1.345

There is no need to utilize the factors along the upward diagonal (i.e., 50°F EAT-220°F EWT & 60°F EAT-210°F EWT).

The equivalent required capacity at standard conditions (180°F water and 60°F entering air) is:

$$Cap_{at\_std\_conditions} = \frac{52.0}{1.345} = 40.9 \text{ MbH}$$

### CALCULATE GPM

$$Q = \frac{Cap_{design} \text{ (MbH)}}{0.5 \times \Delta T_{design}} = \frac{52.0}{0.5 \times 40.0} = 2.75 \text{ gpm}$$

### UNIT SELECTION AND ACTUAL CAPACITY

From the standard hot water capacities (Table 2), at 180°F EWT, model SFF-06 which delivers 39.9 MbH at 2.66 gpm (and 30°F ΔT) meets the capacity requirements. Note, that to utilize this method, the gpm is to be matched as closely as possible (ΔT will vary). To obtain the actual capacity, multiply the capacity (at std conditions) by the correction factor as follows:

$$Cap_{actual} = Cap_{at\_std\_conditions} \times 1.345$$

$$= 39.9 \times 1.345 = 53.7 \text{ MbH}$$

### DETERMINING GPM AND WATER PRESSURE DROP

The required water flow can be found by:

$$Q_{actual} = \frac{Cap_{actual} \text{ (MbH)}}{0.5 \times \Delta T_{actual}} = \frac{53.7}{0.5 \times 40.0} = 2.7 \text{ gpm}$$

The water pressure drop can be approximated using the following equation:

$$\Delta P_{actual} = WPD_{at\_std\_conditions} \times \left( \frac{Q_{actual}}{Q_{at\_std\_conditions}} \right)^{1.8}$$

$$= 1.9 \times \left( \frac{2.7}{2.66} \right)^{1.8} = 1.95 \text{ ft. of water}$$

### DETERMINING FINAL AIR TEMPERATURE

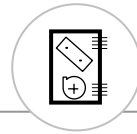
$$FAT_{actual} = EAT + \Delta T_{air} = EAT + \frac{Cap_{actual} \text{ (Btu/hr)}}{CFM \times 1.085}$$

$$= 55^\circ + \frac{53,700}{600 \times 1.085} = 137.5^\circ F$$

**TABLE 3 HOT WATER CORRECTION FACTORS (APPLIED TO 180°F EWT / 60°F EAT CAPACITY DATA)**

Entering Air Temp. (°F)	Entering Water Temperature (°F)												
	100	110	120	130	140	150	160	170	180	190	200	210	220
40	0.495	0.569	0.655	0.743	0.830	0.918	0.989	1.076	1.163	1.250	1.337	1.424	1.512
50	0.404	0.490	0.576	0.662	0.749	0.822	0.908	0.995	1.082	1.168	1.255	1.342	1.429
60	0.325	0.410	0.495	0.581	0.668	0.742	0.828	0.914	1.000	1.086	1.173	1.260	1.347
70	0.245	0.329	0.414	0.499	0.576	0.661	0.746	0.832	0.918	1.004	1.091	1.177	1.264
80	0.164	0.248	0.332	0.417	0.495	0.579	0.665	0.750	0.836	0.922	1.008	1.094	1.181





### FORCE FLOW ORDERING

1. Select the appropriate order form for **Upright & Horizontal Units** (pg. 8) or **Inverted Units** (pg. 9).
2. Fill in appropriate job specific information on the order form (PO No., Job Name, Qty., and Tags).
3. Select **only one** option from each of the items grouped in Section A: Air Flow, Voltage, Inlet/Outlet, Configuration, Handing, Thermostat, and Finish.
4. Select **only required** items from the options in Section B: speed controller, access door (for optional speed controller and unit mounted thermostat), cover safety chains (usually for horizontal ceiling units), recess collars (for semi or fully recessed units), aquastat, and manual starter.

### TYPICAL MODEL NUMBERS

The Sigma force flow model number encapsulates options and accessories relevant to the unit. An example model number is depicted below showing the various options. A full list of options is provided in Table 4.

Position: 1 2 3 4 5 6 7 8 9 10 11 12 13 14 15 16 17 18  
 Code: SFF-A-04-120-FIFO-OLV-ILV-TU-LH-UT-SPD-RC-NSC-AD-MST-AQS-GRY-TAG1

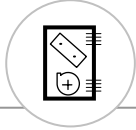
**TABLE 4  
 DESCRIPTION  
 OF CODE  
 OPTIONS FOR  
 FORCE FLOW  
 HEATERS**

POSITION	DEFINITION	CODE OPTIONS
1	Unit designation	SFF = Sigma Force Flow
2	Development series	A
3	Nominal CFM/100	02, 03, 04, 06, 08, 10, 12, 15
4	Voltage	120=120V/1/60Hz, 208=208-230V/1/60Hz
5	Flow configuration	For Upright (TU): FIFO = front in-front out FITO = front in-top out BIFO = bottom in-front out BITO = bottom in-top out For Inverted (BI): FIFO = front in-front out FIBO = front in-bottom out, TIFO = top in-front out, TIBO = top in-bottom out
6	Outlet type	OLV = louvers, OBG = bargrille, ODT = ducted
7	Inlet type	ILV = louvers, IBG = bargrille, IDT = ducted
8	Arrangement	TU = upright, BI = inverted
9	Pipe handing	LH = left hand, RH = right hand
10	Temperature control	UT=unit mounted thermostat, RTI=remote mounted thermostat (imperial units), RTM=remote mounted thermostat (metric units)
11	Speed control	SPD = variable speed controller, NSPD = no controller
12	Collar configuration	RC = recessed collar, EX = exposed collar
13	Safety chain	SC = safety chain, NSC = no safety chain
14	Access	AD = access door, NAD = no access door
15	Starter	MST = manual starter (no overloads) MSO = manual starter with overloads NMS no manual starter
16	Aquastat	AQS = aquastat, NAQ = no aquastat
17	Finish type	NON=no paint, PRM=primer, SNO=snow white, TWHT=tinted white, CMW=cameo white, SFD=soft dove, BGE = beige, GRY=gray, BLK=satin black, CST = custom
18	Tag	As per customer's direction



# Force Flow Heaters

## Plant Order Form - TU Upright & Horizontal Units



PO No.: \_\_\_\_\_

QUANTITY: \_\_\_\_\_

JOB NAME: \_\_\_\_\_

TAGS: \_\_\_\_\_

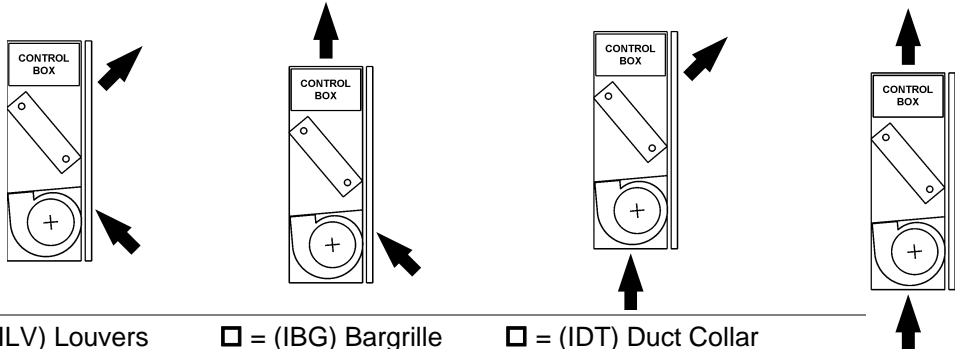
### SECTION A: SELECT ONE OPTION FROM EACH GROUP

**AIR FLOW**       = (02) 200 cfm       = (04) 400 cfm       = (08) 800 cfm       = (12) 1200 cfm  
 = (03) 300 cfm       = (06) 600 cfm       = (10) 1000 cfm       = (15) 1500 cfm

**VOLTAGE**       = (120) 120V/1Ph/60 Hz       = (208) 208-230V/1Ph/60 Hz

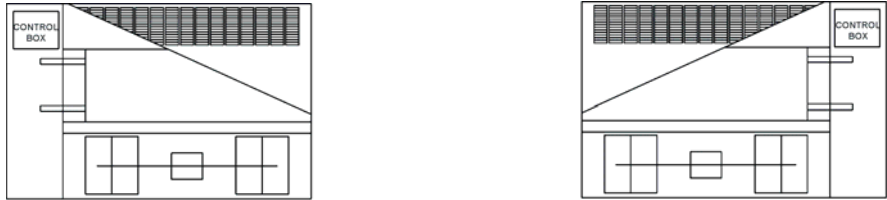
**OUTLET**       = (OLV) Louvers       = (OBG) Bargrille       = (ODT) Duct Collar

**INLET/OUTLET CONFIGURATION**       = (FIFO) Front in/Front out       = (FITO) Front in/Top out       = (BIFO) Bottom in/Front out       = (BITO) Bottom in/Top out



**INLET**       = (ILV) Louvers       = (IBG) Bargrille       = (IDT) Duct Collar

**HANDING**       = (LH) Left Hand Connections       = (RH) Right Hand Connections



**THERMOSTAT**       = (NT) No Thermostat       = (UT) Unit Mounted  
 = (RTM) Remote Mounted (Metric)       = (RTI) Remote Mounted (Imperial)

**MAN. STARTER**       = (NMS) NO Starter       = (MST) Manual Starter (No OverLoads)       = (MSO) Manual Starter with OverLoads

**FINISH**       = (NON) No Paint       = (TWHT) Tinted White       = (BGE) Beige       = (CST) Custom  
 = (PRM) Primer       = (CMW) Cameo       = (GRY) Grey  
 = (SNO) Snow White       = (SFD) Soft Dove       = (BLK) Satin Black

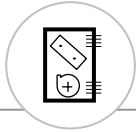
### SECTION B: SELECT ONLY REQUIRED OPTIONS

= (SPD) Speed Control       = (SC) Cover Safety Chain       = (AD) Access Door  
 = (AQS) Aquastat       = (RC) Recessed Collar



# Force Flow Heaters

# Plant Order Form - BI Inverted Units



PO No.: \_\_\_\_\_

QUANTITY: \_\_\_\_\_

JOB NAME: \_\_\_\_\_

TAGS: \_\_\_\_\_

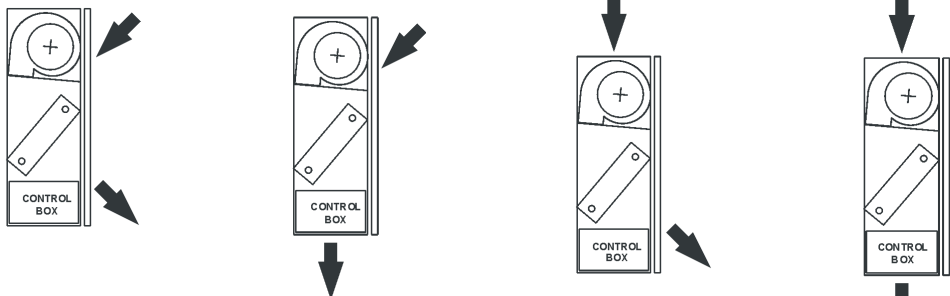
### SECTION A: SELECT ONE OPTION FROM EACH GROUP

**AIR FLOW**       = (02) 200 cfm       = (04) 400 cfm       = (08) 800 cfm       = (12) 1200 cfm  
 = (03) 300 cfm       = (06) 600 cfm       = (10) 1000 cfm       = (15) 1500 cfm

**VOLTAGE**       = (120) 120V/1Ph/60 Hz       = (208) 208-230V/1Ph/60 Hz

**INLET**       = (ILV) Louvers       = (IBG) Bargrille       = (IDT) Duct Collar

**INLET/OUTLET CONFIGURATION**       = (FIFO) Front in/Front out       = (FIBO) Front in/Bottom out       = (TIFO) Top in/Front out       = (TIBO) Top in/Bottom out



**OUTLET**       = (OLV) Louvers       = (OBG) Bargrille       = (ODT) Duct Collar

**HANDING**       = (LH) Left Hand Connections       = (RH) Right Hand Connections



**THERMOSTAT**       = (NT) No Thermostat       = (UT) Unit Mounted  
 = (RTM) Remote Mounted (Metric)       = (RTI) Remote Mounted (Imperial)

**MAN. STARTER**       = (NMS) NO Starter       = (MST) Manual Starter (No OverLoads)       = (MSO) Manual Starter with OverLoads

**FINISH**       = (NON) No Paint       = (TWHT) Tinted White       = (BGE) Beige       = (CST) Custom  
 = (PRM) Primer       = (CMW) Cameo       = (GRY) Grey  
 = (SNO) Snow White       = (SFD) Soft Dove       = (BLK) Satin Black

### SECTION B: SELECT ONLY REQUIRED OPTIONS

= (SPD) Speed Control       = (SC) Cover Safety Chain       = (AD) Access Door  
 = (AQS) Aquastat       = (RC) Recessed Collar





**VIGMARK**

VIGMARK INC.  
7862, Fleuricourt  
Montréal (Québec) H1R 2L3  
**Tél.: (514) 852-0987 Fax: (514) 852-2550**  
**Ligne sans frais / Toll free: 1-800-567-1407**  
Site internet / Web site: [www.vigmark.com](http://www.vigmark.com)  
Courriel / E-mail: [vigmark@vigmark.com](mailto:vigmark@vigmark.com)



SIGMA CORPORATION  
101B, Devon Road  
Brampton (Ontario) L6T 5A4